

All Size Perforating Ltd.

Channel Lock Floor Assembly Instructions

Rules Regarding Warranty

- A. All Size Perforating will not be responsible for damage resulting from improper storage, handling prior to erection, or improper installation of the product.
 - B. All Size channel lock flooring warranty is valid only when the channel lock floor is supported by All Size channel lock supports.
 - C. A flat concrete surface is required to allow proper installation of the channel lock floor. A ½ inch variation from grade over a span of half the concrete diameter with no abrupt irregularities of contour is required. A concave or convex floor voids all warranty.
-

Introduction

Completely read this installation manual before disassembly of packaging. Take note of the floor specification sheets at the back of the manual for the particular floor that you have purchased.

Step 1

Make sure that you have the correct quantity of steel supports for the grain depth to be applied; check to see if they are the right height of support required for your unloading equipment.

Support Chart 20 and 18 Gauge
20 gauge and 18 gauge support counts and spacing according to height of bin.

Bin Eave	18' eave	21' eave	24' eave	27' eave	30' eave	33' eave	36' eave	39' eave	42' eave	48' eave	60' eave
Bin Diameter											
14'	95/46	99/43	102/41	108/38	110/37	114/35	117/34	122/32	125/31	131/29	148/26
15'	108/46	113/43	119/40	123/38	128/36	130/35	136/33	139/32	143/31	150/29	163/26
16'	123/46	127/43	134/40	139/38	144/36	147/35	154/33	157/32	161/31	170/29	185/26
18'	153/45	160/42	166/40	173/38	180/36	184/35	192/33	197/32	201/31	212/29	232/26
19'	168/45	177/42	183/40	191/38	199/36	207/34	212/33	217/32	223/31	235/29	256/26
21'	202/44	209/44	221/39	231/37	236/36	246/34	252/33	259/32	265/31	280/29	307/26
22'	221/44	233/41	242/39	252/37	258/36	270/34	276/33	283/32	290/31	307/29	336/26
24'	260/44	274/41	285/39	297/37	311/35	318/34	326/33	343/31	353/30	363/29	398/26
25'	285/43	296/41	308/39	321/37	336/35	344/34	353/33	371/31	381/30	392/29	430/26
27'	330/43	342/41	364/38	372/37	389/35	399/34	419/32	430/31	444/30	469/29	500/26
30'	405/42	422/40	440/38	460/36	471/35	495/33	509/32	523/31	538/30	571/28	609/26
33'	485/42	516/39	540/37	552/36	580/34	595/33	611/32	628/31	646/30	686/28	758/25
36'	581/41	606/39	634/37	665/35	682/34	700/33	719/32	739/31	761/30	809/28	895/25
40'	726/40	759/38	776/37	815/35	836/34	882/32	907/32	938/30	963/29	993/28	1100/25
42'	793/40	829/38	870/36	891/35	939/33	965/32	993/32	1023/30	1054/29	1088/28	1206/25
48'	1051/39	1101/37	1128/36	1187/34	1219/33	1254/32	1290/31	1329/30	1371/29	1463/28	1570/25

All bins 30' and over 18 gauge supports required.

**** IMPORTANT NOTICE FOR UNLOAD AUGERS ****

If adding an unload auger, add one support for each plack beside the augers, staggering them from side to side of the auger.

Pounds Per 20 Gauge Support					
13"	1.97 lbs.	10"	1.504 lbs.	6"	.887 lbs.
Pounds Per 18 Gauge Support					
13"	2.57 lbs.	10"	1.967 lbs.	6"	1.16 lbs.

Step 2

Study the layout of the floor assembly to determine proper position of the floor sections with respect to the unloading tube and transition. The unloading tube should run at a 90° angle to the floor pieces and the transition should be as close to a 90° angle as possible at opposite end of the unloading auger. Locating the transition within 25° of the bin centreline yields the best air distribution.

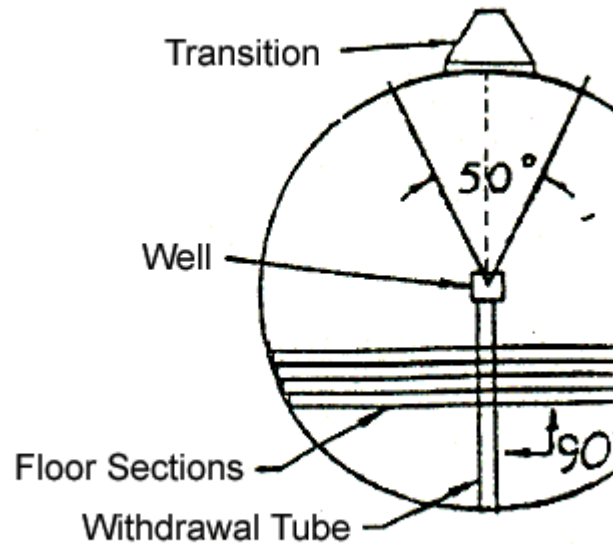

Step 3

Locate the centre of the bin, and chalk a line on the same centreline as the unloading tube. Place the channel section with corresponding supports for board #1 in the bin. An equal length of row #1 must be on each side of the chalk line.

If the bin is slightly out of round, it may be necessary to trim the corners of the floor section for row #1 and the next couple of succeeding rows.*

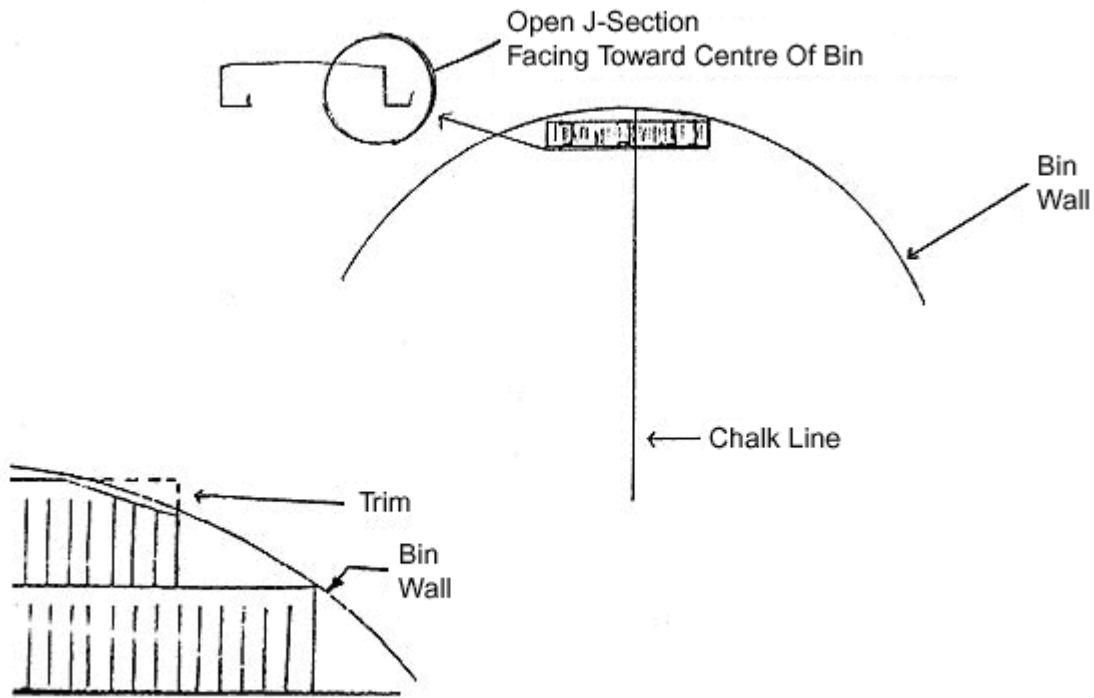

*Make sure the floor is located so that the open J-section of the channel floor section is toward the centre of the bin.

Step 5

Place the next floor section into the position to locate the supports for the succeeding row and snap the channel in place as indicated in Step 4. Once you have installed 4-5 rows of channel lock floor, anchor the assembled floor section to the bin wall by assembling flashing sections as indicated in Step 6. The flashing is attached to the assembled rows and bin wall anchoring the floor from movement. continue to assemble remaining floor sections and supports according to the appropriate floor measurement sheet provided.

IMPORTANT: Supports must be located as per measurement sheet and stand vertically under the floor section. Verify that the supports under the floor section are located properly.*

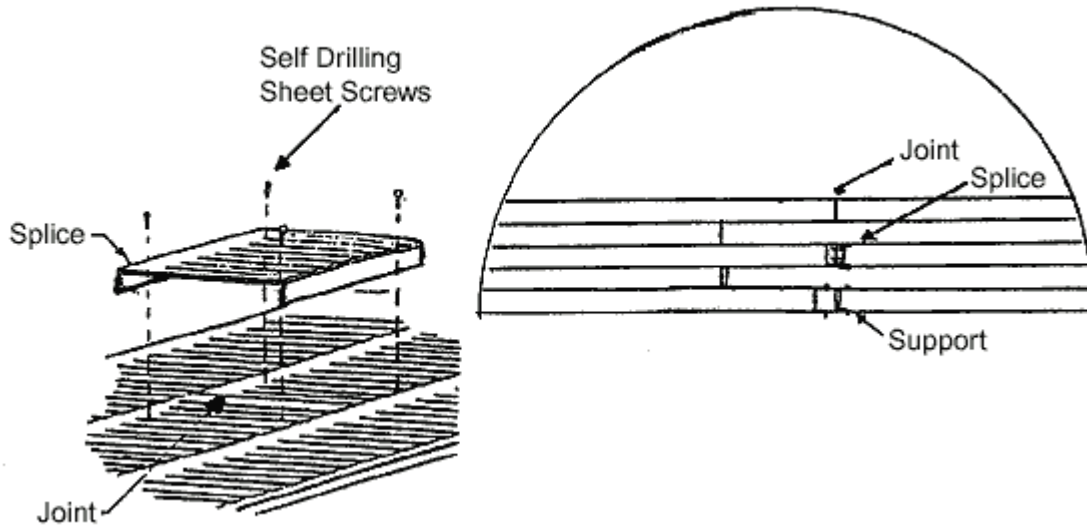

* On larger floors, an individual row may be shipped with more than 1 bin floor section to span the diameter. These floor sections are not of equal length to allow offsetting of joints. Splices are used to secure the joint.

Floors that are to be spliced are packaged as follows.

Each Package has each board together in the way that each should be butted together with a splicer.

There are two boards inside one another which would make them to be one single board when butted together for the total length of the board.

For 42' and 48' full floors there are 48 planks that should be spliced together which should include 48 splicers per floor and four screws per splicer.

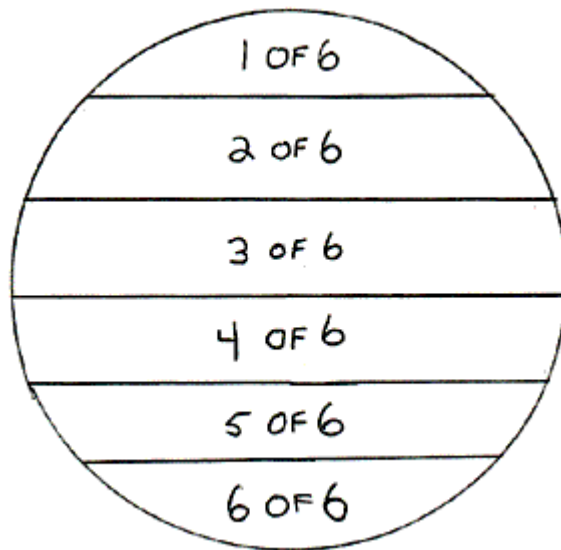

Channel lock floors with spliced planks

The following instructions are for special floors where a particular length has been cut into 2 pieces, the longest channel supplied for ease of shipment. In doing so, seams and splices are created. If you have a spliced floor it is important to read the following instructions below, if not the instructions may be disregarded.

- A. An additional is required for each seam. A leg is to be placed on every seam, every channel.
 - B. The splices are to be staggered as shown in the diagram in Step 5 to prevent the seams from being in a straight line.
 - C. There are to be 4 self-tapping screws required to fasten the splices over the seams. 4 per splice, one in each corner are required.
-

Step 6

Attach the remaining flashing to the bin wall and channel lock floor using the $\frac{3}{4}$ " self-tapping screws provided. Also secure the centre well to the floor sections with the same screws.*

Important: Overlap the flashing so that the sweep auger wheel must climb up over the lead edge of the following flashing piece.

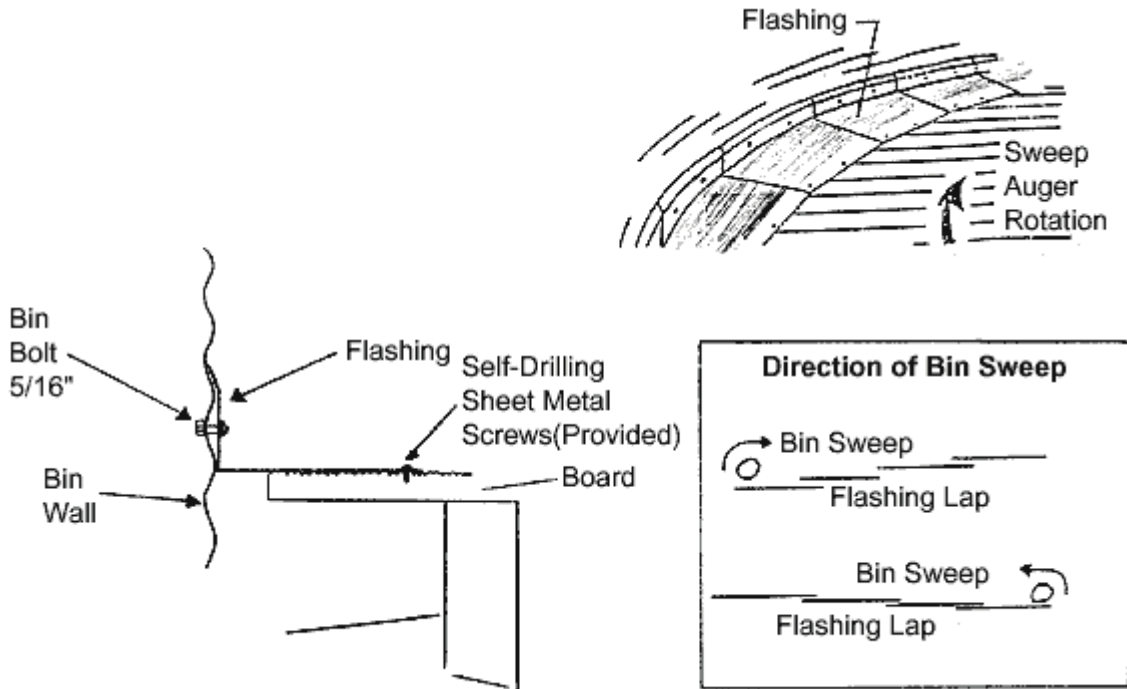

You may use the bin bolts to fasten the pre-punched flashing to the bin wall instead of the self-tapping screws. It will make for a stronger hold, especially on larger bins.

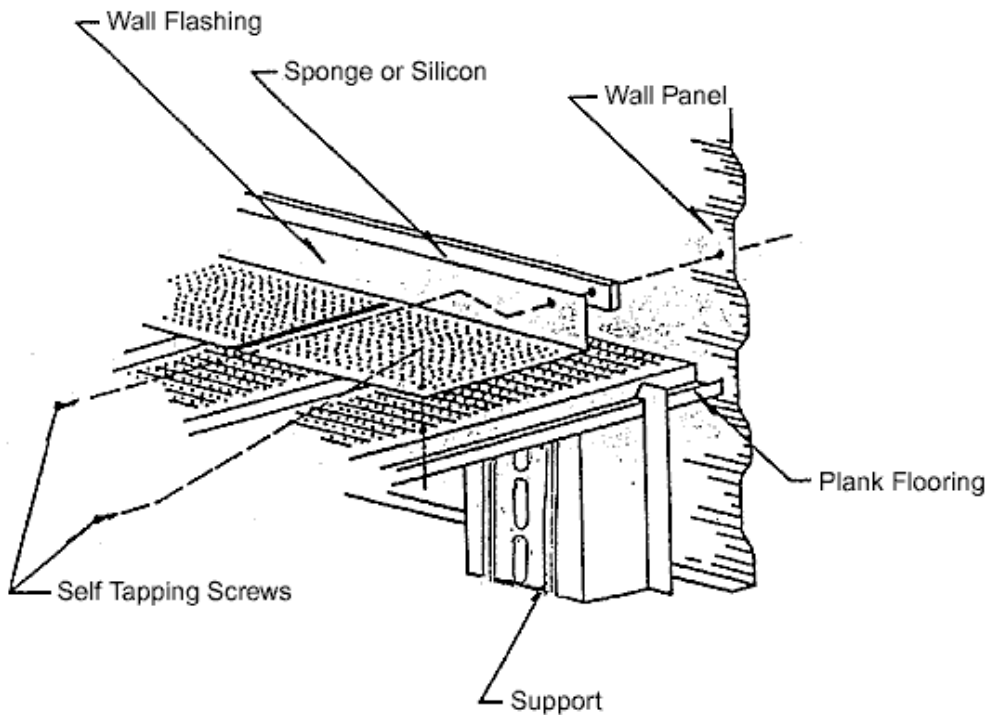

Grain Bin Floor Plans For Drying or Aeration

DIM. C	DIM. D	# OF PLANKS	# OF SUPPORTS
8'	99"	14	35
10'	120"	17	53
12'	141"	20	76
14'	169"	24	106
16'	190"	27	136
18'	218"	31	176
20'	239"	34	215

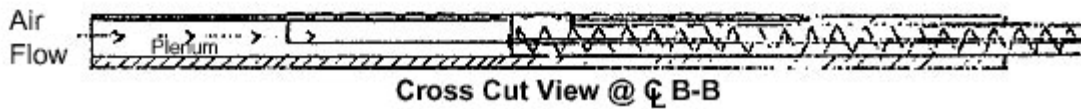
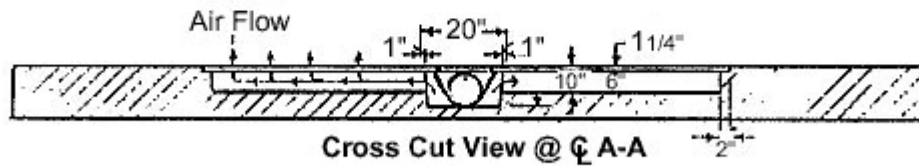
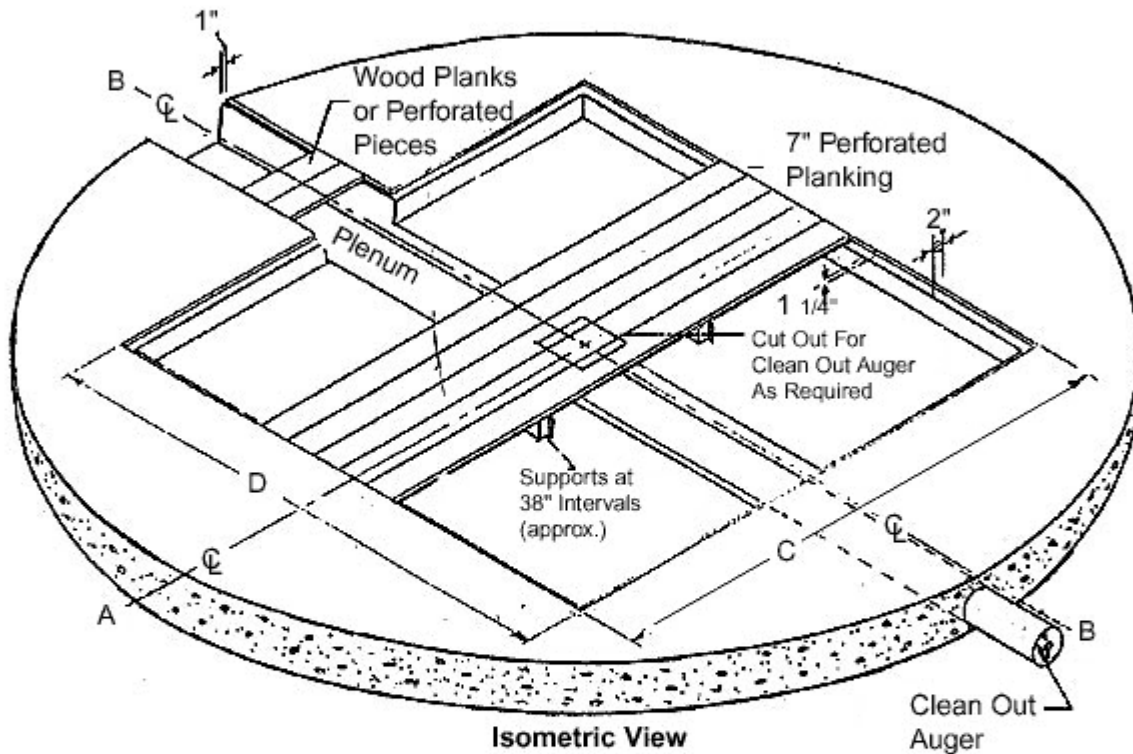

Grain Bin Floor Plans For Drying or Aeration

No Supports Required

DIM. C	DIM. D	# OF PLANKS
8'	99"	14
10'	120"	17
12'	141"	20
14'	169"	24
16'	190"	27
18'	218"	31
20'	239"	34

NO SUPPORTS REQUIRED

